

Blattfeuchte-Sensor

Leaf wetness sensor



Robuster Sensor / *robust sensor*

Feuchtebestimmung auf der Ober-und Unterseite /

wetness detection at the top and bottom side

Für kleinste Tropfen / for smallest drops

Wasserdicht / waterproof

Analogausgang 0,5...3V /analog output 0,5...3V; RS485 Interface

Für weitere Informationen / for further questions

messtechnik@marvitech.de / +49-38852 233224

Characteristics

- Reliable reproduction of the thermodynamic properties of a leaf
- Capacitive measurement principle for an accurate detection of even the smallest drops of water
- Double sensitive surface
- High resistance to chemical and atmospheric agents
- It can be installed in the field thanks to the IP67 degree of protection

APPLICATIONS

- Agriculture
- Floriculture
- Study of phytopathogen models forecasting

Description

The HD3901 leaf wetness sensor detects the presence of condensation on its sensitive surface and has been designed to reproduce in an extremely accurate way the thermodynamic behaviour of a leaf.

The leaf wetness degree is a basic information in the agricultural and floriculture fields to determine the most appropriate phytosanitary treatment to prevent mould and fungal infections in general that can affect the plants and crops in the presence of condensation on the leaves.

The double sensitive surface allows to determine the wetness degree both on the top and on the bottom of the leaf, important feature to get accurate indications, being that the two sides of the leaf have different drying times.

In order to ensure a long duration of the sensor, the surface of the sensor is specially treated to resist to the atmospheric agents and to the chemical agents present in pesticide products.

The circuit board, protected inside a sealed housing made of plastic material, allowing to achieve reliable measurements even in environments with high condensation. The sensor is already supplied with factory-calibration and does not require any calibration by the user. The output is 0.5 ... 3 V analog voltage with a fixed 5 or 10 m connecting cable. Power supply 5... 18 Vdc.

Operating principle

On the sensitive surface of the sensor, two grid-shaped electrodes are placed. The sensor detects the change of the dielectric constant between the two electrodes caused by the presence of water drops on the surface.

Thanks to its operation principle, the sensor HD3901 is able to detect even the presence of small water droplets, unlike common sensors which are based on the resistance or conductivity measurement, which require of the drop of water to be detected between the two electrodes (a minimum size).

The construction materials and the white colour of the sensitive-surface have been chosen to simulate, in the most reliable way as possible, the thermal and radiative properties of a real leaf.

The 0.5 ... 3 V analog voltage output corresponds to the degree of wetness 0 ... 100%. The degree (percentage) of wetness indicates how much sensitive surface is covered by the water compared to the total surface of the sensitive area.

Technical characteristics

Measurement principle	Capacitive
Measurement Range	0...100% of leaf area wetness
Accuracy	± 5%
Power Supply	5...18 Vdc
Consumption	< 1 mA
Output	Analog 0.5...3 V
Operating Temperature	-30...+60 °C
Dimensions	61 x 115 x 11 mm (excluding cable). Width of the sensor 1.6 mm
Cable	4 poles with open wires at the end, length 5 or 10 m to be defined when ordering
Weight	About 100 g (including the 5 m cable)
Protection Degree	IP67

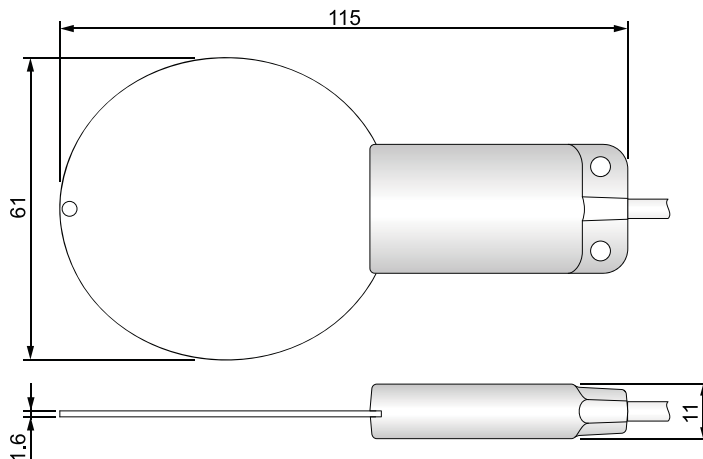

Fig. 1: dimensions (mm)

Sensor installation

The sensor can be positioned inside the foliage of the plant (the optimal position depends on the type of plant, but preferably place it on the layer of the outer foliage) or it can be fixed to a meteorological station mast placed in proximity of the cultivation. Place the sensor with the sensitive surface facing upwards and fix it with a clamp or screws using the two holes in the plastic support near the cable. One of the two sensitive surfaces is distinguished by the **H** (High) symbol placed near the hole at the end of the sensor. The two surfaces are functionally identical, but it is convenient to position the surface with the **H** symbol facing upwards to remember more easily the arrangement of the two surfaces.

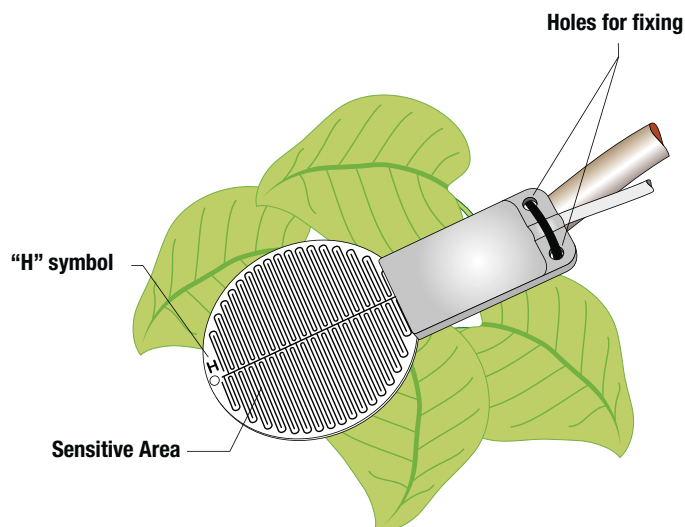

Fig. 2: example of installation

The sensor should be inclined at about 30 ÷ 45 ° with respect to the ground, so as to prevent the stagnation of condensation or rain water on the sensitive surface and simulate the real condition of the leaf type of the cultivation under examination. In case of installation on a meteorological station, fix the sensor to a proper angle stirrup.



Make sure that the sensitive surface is not in contact with leaves, branches or other objects.

Connect the cable to an instrument or datalogger with analog voltage input and power the sensor according to the colour coding shown in figure 3.

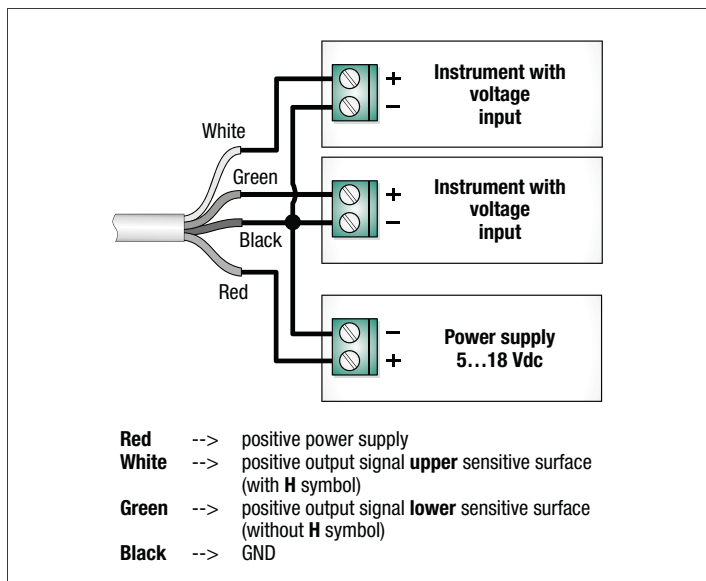

Fig. 3: electric connection

DYNAMICS OF THE LEAF WETNESS DEGREE

To detect the foliage wetting and/or drying time, connect the sensor to a data logger with at least two voltage analog inputs (for example HD32MT.1, HD32MT.3 or the wireless data logging system HD35...), then start the recording of the measurements in the data logger. By regularly checking the recorded data, it is possible to analyze and keep under control the time behaviour of the foliage wetness degree.

Note: if the full scale of the data logger voltage analog input is lower than 3 V, place a resistive divider between the sensor and the data logger to reduce the input voltage of the data logger.

Maintenance

The sensor does not require special maintenance. We recommend a periodic cleaning of the sensitive surface with water and normal detergent in order to avoid the accumulation of antiparasitic substances or other elements present in the air that could alter the measurement of the sensor.

ORDERING CODES

HD3901.5: Leaf wetness sensor with double sensitive surface. Two analog outputs 0.5...3 Vdc (one output for each of the two sensitive surfaces). Power supply 5...18 Vdc. Protection Degree IP 67. Complete with 4 poles 5 m cable with open wires at the end.

HD3901.10: Leaf wetness sensor with double sensitive surface. Two analog outputs 0.5...3 Vdc (one output for each of the two sensitive surfaces). Power supply 5...18 Vdc. Protection Degree IP 67. Complete with 4 poles 10 m cable with open wires at the end.



Manufacture of portable, bench top and process scientific instruments
Current and voltage loop transmitters and regulators
Temperature - Humidity, Dew point - Pressure - CO, CO₂
Air speed - Light - Optical Radiation
Acoustics - Vibration
Data logger - Data logger wireless
Microclimate
pH - Conductivity - Dissolved Oxygen - Turbidity
Elements for weather stations



LAT N° 124 Signatory of EA, IAF and ILAC Mutual Recognition Agreements
Temperature - Humidity - Pressure - Air speed
Photometry/Radiometry - Acoustics

CE CONFORMITY

- **Safety:** EN61000-4-2, EN61010-1 Level 3
- **Electrostatic discharge:** EN61000-4-2 Level 3
- **Electric fast transients:** EN61000-4-4 Level 3, EN61000-4-5 Level 3
- **Voltage variations:** EN61000-4-11
- **Electromagnetic interference susceptibility:** IEC1000-4-3
- **Electromagnetic interference emission:** EN55022 class B

